



.....	2
.....	2
.....	6
.....	8
.....	10
.....	10
.....	13
.....	16
.....	19
.....	22
.....	24
.....	24
.....	26
.....	28
.....	29
.....	32
.....	33
.....	34
.....	35
.....	38
.....	40
.....	43
.....	43
.....	44
.....	46
.....	49
.....	51
.....	53

5A

W₂

W₁



图1 电流互感器原理线路

I₂

$$K = I_1 / I_2$$

K

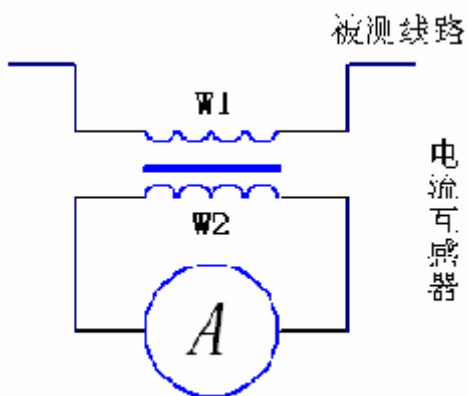
I₁

I_{1n}

I_{2n}

Kn

$$K_n = I_{1n} / I_{2n}$$

A

1

5 25000A

4 10

1 A

1	—	—	—	—	—	—	5	—	—
10	—	15	20	—	30	40	50	60	75
100	—	160 150	200	—	315 300	400	500	630 600	800 750
1000	125 1200	1600 1500	2000	2500	3150 3000	4000	5000	6300 6000	8000 7500
10000	12500 12000	16000 15000	20000	25000					

1A 5A

[2] 1 0.1

0.15 0.2 0.25 0.3 0.35 0.4 0.5 0.75 1.5 2 2.5 3 4 7.5 8 25

80 120 250 1A 5A 0.5A

0.03 0.04 0.05 0.075A 0.1A 0.01 0.015 0.02 0.025

0.1A 0.05A

2

$K_n = I_{1n} / I_{2n} = 5/5$ 10/50.1/5 5/1 5/0.05 3

$K = K_n = I_1 / I_2$ 4

100/5

20

5A 100/5 20/1 20/1

20A 1A 100/5

1

0.05 0.1 0.2 0.5 1 3 5

0.01 5

5

5

$\pm 1\%$ $\pm 3\%$

0.5A

1 2 4 8 10
50 100

0.1 0.05A

1

5

0.5 10 15

20 35 60 110 220 330KV

2

2

KV	0.5	10	15~20	35
A	5~25000	5~6000	800~15000	15~1500
KV	60	110	220	330
A	20~600	75~2000	300~1200	300~1200

KV

LA-10 10KV

[5] LMZJ-0.5

10VA

6

$$Z_n = S_n / 25 = 10 / 25 = 0.4$$

[6] 5LMZJ-0.5

0.5

0.5 KV

500V

[7]

0.2

6

10KV

0.2



图3 圆环形铁心



图2 方形叠片铁心

2

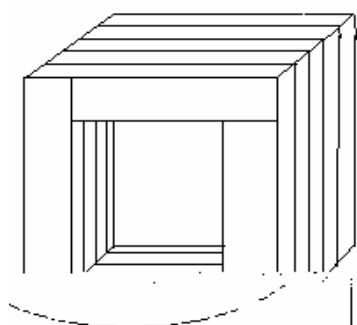
3

0.2

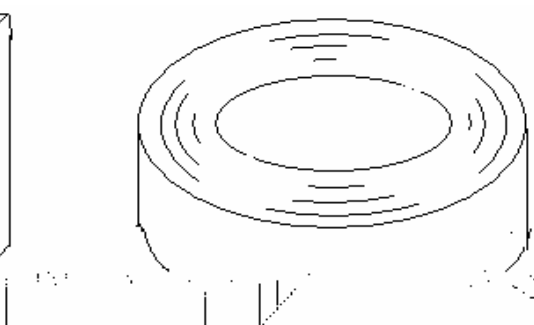
300 600A

LA-10

300 1000A

600A

LMZJ-0.5

100A 1

2 3 4.....

300 600A

8

LQG-0.5

LFC-10

8

LCW-35 8 110 220

35KV

10KV

35KV

1

$E_1 I_1 = E_2 I_2$

1000

[17]

HL46-11 5~5000/5

5

5 HL46-11

4

5 HL46-11

A			A		
5000	LaLb=1	K ₁ K ₁₁	250	L ₁ L ₂	K ₁ K ₄
4000		K ₁ K ₁₀	200		K ₁ K ₂
3000		K ₁ K ₈	150		L ₁ L ₃
2500		K ₁ K ₇	100	K ₁ K ₆	
2000		K ₁ K ₆	75	K ₁ K ₅	
1500		K ₁ K ₅	60	K ₁ K ₃	
1250		K ₁ K ₄	50	K ₁ K ₂	
1200		K ₁ K ₃	40	L ₁ L ₄	
1000		K ₁ K ₂			30
800	L ₁ L ₂	K ₁ K ₁₀			25
750		K ₁ K ₉	20		K ₁ K ₆
600		K ₁ K ₈	15		K ₁ K ₅
500		K ₁ K ₇	10		K ₁ K ₂
400		K ₁ K ₆	7.5	L ₁ L ₅	K ₁ K ₄
300		K ₁ K ₅			5

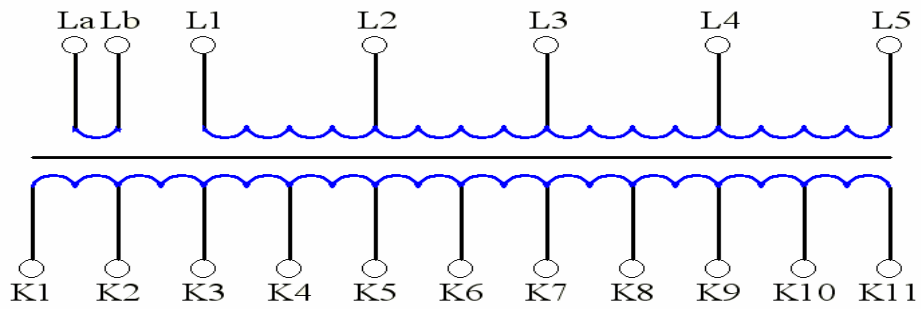

4 HL46-11

$L_1 \ L_2 \ \dots$ $K_1 \ K_2 \ \dots$ L_1L_x
 L_yL_x $K_1K_x \ \ K_yK_x$ 5
 $L_1L_x \ \ K_1K_x$
 $LaLb=1 \ \ \ \ \ 1 \ \ \ \ \ 1$

$K_1K_2 \ \ 1000 \ \ \ \ \ \ W_{12}=1000/5=200$
 $K_1K_3 \ \ 1200 \ \ \ \ \ \ W_{13}=1200/5=240$

K ₁ K ₄	1250	W ₁₄	=1250/5=250
K ₁ K ₅	1500	W ₁₅	=1500/5=300
K ₁ K ₆	2000	W ₁₆	=2000/5=400
K ₁ K ₇	2500	W ₁₇	=2500/5=500
K ₁ K ₈	3000	W ₁₈	=3000/5=600
K ₁ K ₁₀	4000	W ₁₁₀	=4000/5=800
K ₁ K ₁₁	5000	W ₁₁₁	=5000/5=1000

L ₁ L ₂ /K ₁ K ₁₀	=800/5	L ₁ L ₂	W ₂₁	=4000/800=5
L ₁ L ₃ /K ₁ K ₈	=150/5	L ₁ L ₃	W ₃₁	=3000/150=20
L ₁ L ₄ /K ₁ K ₁₀	=40/5	L ₁ L ₄	W ₄₁	=4000/40=100
L ₁ L ₅ /K ₁ K ₂	=5/5	L ₁ L ₅	W ₅₁	=1000/5=200
K ₁ K ₉				
L ₁ L ₂ /K ₁ K ₉	=750/5	W ₁₉	= 750*5 /5=750	

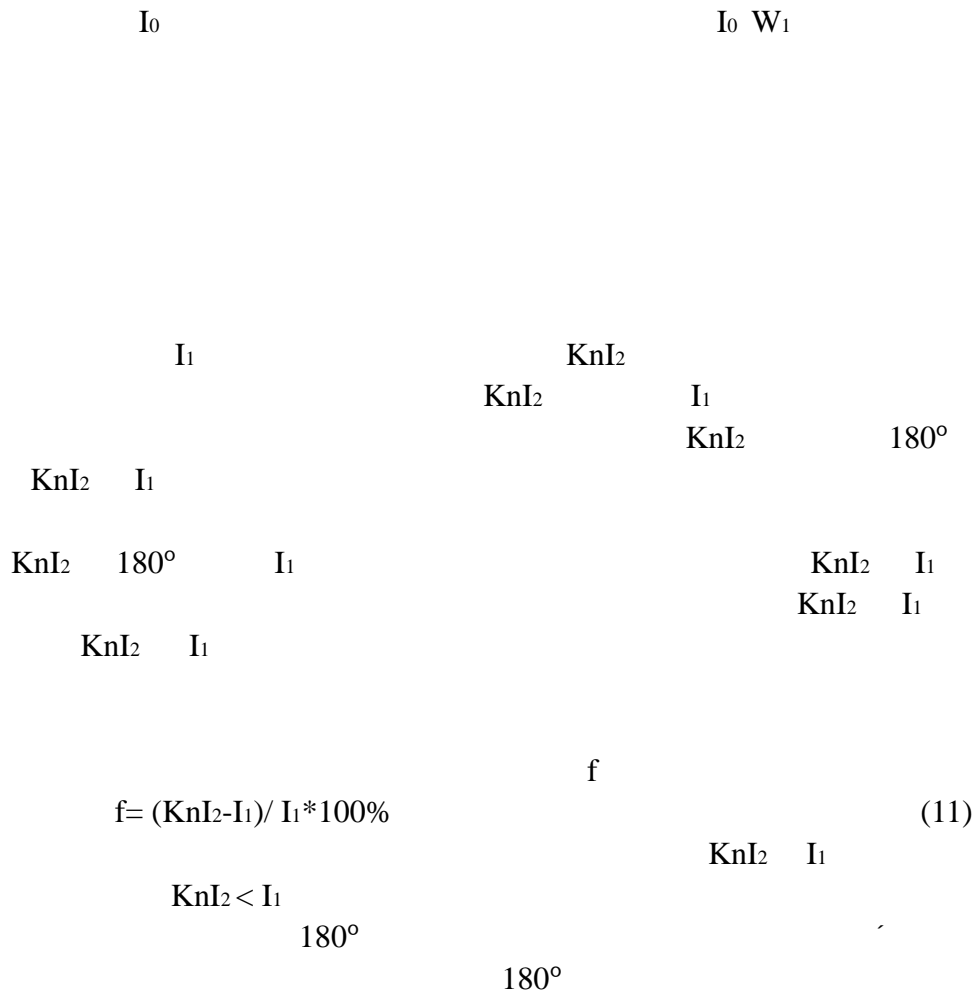

0.2S

0.5S
7

S

5A

25 50 100A

7
10

5P 10P P ,

			cos				
		0.8			0.8	1	5VA
0.05	1						0.8~1
	0.8	1			1		
[18]		20VA		5A			
		$Z_n = S_n / 25 = 20 / 25 = 0.8$					
		$Z_x = 25\% * Z_n = 25\% * 0.8 = 0.2$					
	0.8	0.2					
[19]		10VA		5A			
		$Z_n = S_n / 25 = 10 / 25 = 0.4$					
		$Z_x = 25\% * Z_n = 25\% * 0.4 = 0.1$					
	0.15	0.15		0.15			0.15

Kn

		$E_1' = K_n * E_1$					13
		$I_1' = I_1 / K_n$					14
		$Z_1' = K_n^2 Z_1$					15
	E_1	I_1	Z_1			E_1	I_1
			E	I			$ E_1 $
$ I_1 $		Z				cos	
		$E_1' = E_2$					16



图5 电流互感器等值电路图

$$\begin{aligned}
 U_2 &= I_2 * Z & (17) \\
 Z_{02} &= Z + Z_2 & (18) \\
 E_2 &= U_2 + I_2 Z_2 = I_2 (U_2 + Z_2) = I_2 Z_{02} & (19) \\
 I_0 &= -E_1 / Z_m \quad I_0' = -E_2 / Z_m' & (20) \\
 I_0' &= I_1' + I_2 & (21) \\
 U_1 &= I_1 Z_1 - E_1 & (22)
 \end{aligned}$$

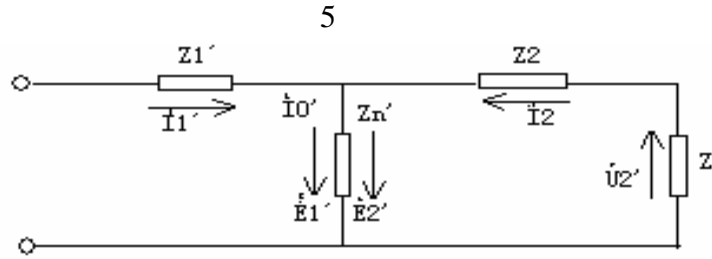

图6 电流互感器相量图

$$\begin{aligned}
 B &= \frac{E_2 * 10^2 * 10^2}{222 W_2 S k} = 45 E_2 / (W_2 S k) \quad T & (23) \\
 1T &= 10000Gs \\
 k &= 0.8 \sim 0.9, \\
 E_2 & 90^\circ
 \end{aligned}$$

		B		H	H	A/cm	
		=B/H		H=B/			24
		B					2
		=B/(1.414*H)					25
B	T	Gs	H	A/cm	T/A/cm	Gs/A/cm	
/	T/Oe		/	Gs/Oe	1A/cm=0.4	Oe.	
		=B/1.414*0.4	H	5.627B/H			26
H	T/Oe	Gs/Oe	H	A/cm			
	B					H	
		H	B	H/B			
						H/B	
		I ₀ W ₁ =H _i					
I ₀ W ₁				A		l	
	cm	I ₀	H		H	I ₀	I ₀ W ₁
I ₀ W ₁ /I ₁ W ₁							
	21			I ₁ '			
				I ₁ ' = -I ₂ + I ₀ '			27
	22)			I ₁ '		U ₁	
				U ₁		U ₁	
				I ₁ ' - I ₂		I ₀ '	I ₁ '
I ₁ '		f		I ₁ ' - I ₂		I ₀ '	I ₁ '
		a		- I ₂		b	ob
c	I ₁ '	abc		cab= +			f
		f= I ₂ -I ₁ ' /I ₁ '		-cb /I ₁ ' = -(I ₀ /I ₁)sin(+)			*100%
		sin = <u>ca</u> /I ₁ ' = (I ₀ /I ₁)cos(+)					*3438'
				2°		sin I ₂ -I ₁ '	-cb=-I ₀ 'sin(+)
I ₀ 'cos(+)	sin	= <u>ca</u> /I ₁ '		(rad)	1rad	3438'	<u>ca</u> =
30	3438					I ₀ '/I ₁ '=I ₀ /I ₁ ,	
:							
		I ₀ /I ₁ =I ₀ W ₁ /I ₁ W ₁		I ₀ W ₁ /I ₂ W ₂			
				I ₂	x	I ₀ '	I ₀ /I ₁
I ₀ /I ₁		x	y				
	X=	I ₀ /I ₁	cos	90°+ +)		= -(I ₀ /I ₁)sin(+)	31

$$Y = I_0/I_1 \sin(90^\circ + \phi) = -(I_0/I_1)\cos(\phi) \quad 32$$

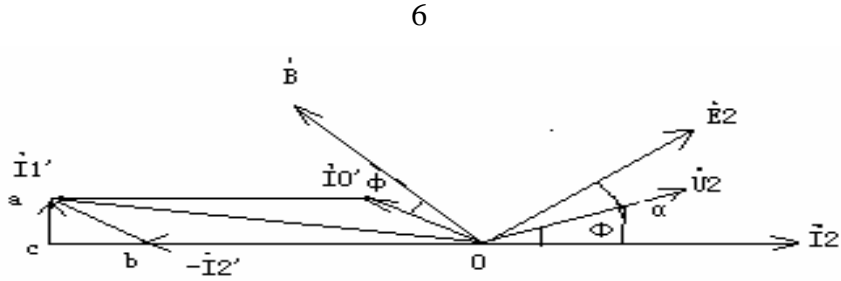
$$f = x * 100\% \quad 33$$

$$= y * 3438' \quad 34$$

$$I_0/I_1 = (x - jy)$$

$$= f + j = x + jy \quad 35$$

$$R \quad X \quad Z \quad Z \quad Z = R + jX$$

180°

$$= [-KnI_2 - I_1 / I_1] * 100\% = -(I_0 N_1 / I_1 N_1) = -(I_0/I_1) * 100\% \quad 36$$

19

$$E_2 = -I_0' Z_m = I_2 Z_{O2} \quad 37$$

$$-I_0' / I_2 = Z_{O2} / Z_m' \quad 38$$

$$I_1' \quad I_2 \quad 36 \quad 39$$

$$= -I_0' / I_1 * 100\% = -Z_{O2} / Z_m' * 100\%$$

$$: \quad = I_0/I_1 = Z_{O2} / Z_m' \quad 40$$

90°-

$$\pm 180^\circ \quad = -90^\circ - +180^\circ = 90^\circ + \quad 41$$

$$6 \quad I_0$$

$$19 \quad 23 \quad 26 \quad 40$$

$$= I_0 W_1 / I_1 W_1 = 0.5627 * 45 Z_{O2} / W$$



29 30 $\sin(+)$ $\cos(+)$

2

43

300~600A 300A
600 800 900

120 160 180

3

43

4

43

0.2

2~4

1/2 1/3

LMZ-0.5 LA-10

6

43

Z

29 30

sin(+)

cos(+)

Z R X Z R X
7 Z R

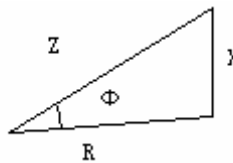

7

cos = R/Z 44

sin = X/Z 45

Z=R/ cos =X/ sin = R²+X² 46

cos =1 R=Z X=0 cos =0.8 R=0.8Z X=0.6Z

[20]

R₂=0.1 X₂ 0

Z=0.4 cos =0.8

Z₀₂

44

45

46

44

45

44

45

Z

R=Z cos =0.4*0.8=0.32

X=Z sin =0.4*0.6=0.24

R₀₂=R₂+R=0.1+0.32=0.42

X₀₂=X₂+X=0+0.24=0.24

46

45

Z₀₂= R₀₂²+X₀₂² = 0.42²+0.24² =0.483

5%

10%

120%

X2 0.400/5

$W_2=400*1/5=80$
 $25*10mm^2$
 $10+3]=82mm$
 $86mm$ $50^\circ C$ $0.02 mm^2/m$

$R_2= L/A=0.02*6.9/1.7=0.08$
 $Lwei$ m A mm^2
 $L=80*86=6900mm=6.9m$
 $A=2* /4 *1.04^2=1.7mm^2$
 0.1

18 21 5% 10% 120%In

9

9

In %	E ₂ V	B Gs	H A/cm	°	I ₀ W ₁ A	%	+ °	F %	'
5	0.121	303	0.016	27	0.376	1.88	56.7	-1.57	+35.5
10	0.242	605	0.024	32	0.584	1.41	61.7	-1.24	+22.8
120	2.90	7300	0.14	59	3.3	0.69	88.7	-0.69	0

10%In 20 23 120%In

$E_2=I_2Z_{02}=120\% I_2nZ_{02}=6*0.483=2.90V$

$B=45E_2/(W_2Sk)=45*2.9/(80*2.5*0.9)=0.73T=7300Gs$

B340B-H -H B=7300Gs H|=0.14A/cm =59°

$I_0W_1=Hl=0.14*23.5=3.3A$

$= I_0W_1/ I_1W_1=3.3/ 120\%*400 =3.3/480=0.0069=0.69\%$

$+ = 59^\circ +29.7^\circ = 88.7^\circ$

$f=- *sin(+)*100=-0.0069*sin88.7^\circ*100 -0.69\%$

$= *cos(+)*3438=0.0069*cos88.7^\circ *3438 0(^\circ)$

9

1

[24]

$0.15 \cos =0.8$

$R=Z\cos =0.15*0.8=0.12$

$X=Z\sin =0.15*0.6=0.9$

$R_{02}=R_2+R=0.1+0.12=0.22$

$X_{02}=X_2+X=0+0.09=0.09$

$Z_{02}= (R_{02}^2+X_{02}^2)= (0.22^2+0.09^2)=0.238$

$\sin =X_{02}/Z_{02}=0.09/0.238=0.378$

$=22.2^\circ$

5% 10% 120%In

10

10

In %	E ₂ V	B Gs	H A/cm	°	I ₀ W ₁ A	%	+ °	F %	'
5	0.06	145	0.009	22	0.212	1.06	44.2	-0.74	+26.2
10	0.119	290	0.016	28	0.376	0.94	50.2	-0.72	+20.4
120	1.43	3500	0.09	51	2.12	0.44	73.2	-0.42	+4.4

9 10

6 7

9

f

f'

$$f' = f + f' \%$$

$$f' = +$$

47

48

f

9 10

W₂ W_X

I₂ W₂-W_X I₂' W_X

I₂'-I₂

W_X

I₂'-I₂

9 10

$$I_2 W_2 = I_2' W_2 - W_X$$

$$I_2' = I_2 W_2 / W_2 - W_X$$

49

50

$$I_2 = I_2' - I_2 = I_2 \left[\frac{W_2}{W_2 - W_X} - 1 \right] = I_2 \frac{W_X}{W_2 - W_X} \quad 50$$

$$f = \frac{I_2}{I_2} * 100 = \frac{W_X}{W_2 - W_X} * 100 = \frac{W_X}{W_2} * 100 \% \quad 52$$

$$\frac{W_X = 1}{52} \quad \frac{W_X}{W_2} \quad \frac{W_X}{W_2} \quad \frac{W_X}{W_2 - W_X} \quad \frac{W_X}{W_2}$$

$$\frac{W_2}{47} \quad 48$$

$$f' = f + \quad f = f + \quad \frac{W_X}{W_2} * 100\% \quad 53$$

$$f' = + \quad = \quad ' \quad 54$$

O

$$[\quad 25] \quad 1000/5$$

$$W_2 = 1000 * 1/5 = 200$$

52

$$f = \frac{W_X}{W_2} * 100 = 1/200 * 100 = 0.5\% + 0.5\%$$

$$[\quad 26] \quad 400$$

$$W_2 = 400/5 = 80$$

$$f = \frac{W_X}{W_2} * 100 = 1/80 * 100 = 1.25\%$$

$$400 \quad +1.25\%$$

$$[\quad 27] \quad 9 \quad 10 \quad 400/5$$

$$26 \quad 400/5$$

$$+1.25\% \quad 9 \quad 10 \quad 53$$

11

$$11 \quad 10\% \ln \quad :$$

$$f' = f + \quad f = -1.24 + 1.25 = 0.01\%$$

11

	%ln	F(%)	f(%)	f' (%)
	5	-1.57		
0.4	10	-1.24		
	120			

B

8 A

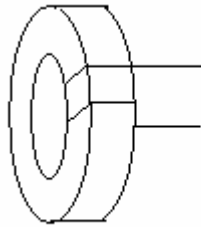

A 两匝

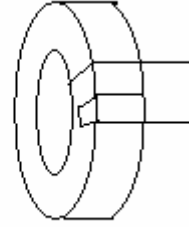

B 一匝

8

27

1

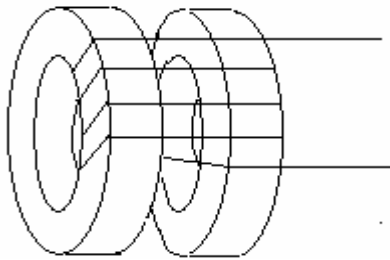

9

9

$$f = \frac{1}{W_2} * \frac{S_b}{S} * 100\%$$

55

S_b
55

S

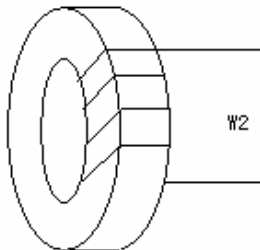

10

1/n,

1/n

图10 铁心穿孔

$$f = \frac{1}{W_2} * \frac{S_b}{S} * \frac{1}{l_b} * 100\%$$

56

l l_b
56

56

2

55

$$f = \frac{1}{W_2} \cdot \frac{R_u}{R_b + R_u} \cdot 100\%$$

$$f = \frac{1}{W_2} \cdot \frac{R_u}{R_b + R_u} \cdot 100\%$$

57

$$f = \frac{1}{W_2} \cdot \frac{A_b}{A_b + A_u} \cdot \frac{D_u}{D_b} \cdot 100\% = \frac{1}{W_2} \cdot \frac{D_b^2}{D_b^2 + D_u^2} \cdot 100\%$$

57

58

W_2

11

$$f = \frac{1}{W_2} \cdot \frac{r}{R_b + R_u + r} \cdot 100\%$$

59



图11 可调的分数匝补偿

[28] 10/5 600

$$W_2 = 600 / I_2 = 600 / 5 = 120$$

$$f = 1/2 \cdot \frac{1}{W_2} \cdot 100 = 1/2 \cdot 1/120 \cdot 100 = 0.416\% + 0.416\%$$

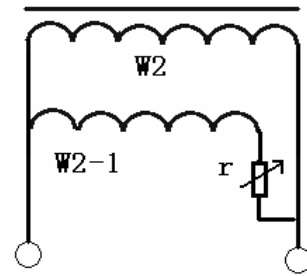
[29] 500

$$W_2 = 500 / I_2 = 500 / 5 = 100$$

$$f = 1/2 \cdot \frac{1}{W_2} \cdot 100 = 1/2 \cdot 1/100 \cdot 100 = 0.5\% + 0.5\%$$

[30] 400

1.04

$$W_2 = 400 / I_2 = 400 / 5 = 80$$

$$f=1/3 * 1/W_2 * 100=1/3 * 1/80 * 100=0.416\%$$

+0.416%

[31] 27

$$f=2/3 * 1/W_2 * 100=2/3 * 1/80 * 100=0.832\%$$

0.832%

[32] 9 10 400/5

9 10 400/5

1.04

$$f=1/2 * 1/W_2 * 100=1/2 * 1/80 * 100=0.625\%$$

9 10

47

12

12

	%In	f (%)	f(%)	f' (%)
0.4	5	-1.57	+0.625	-0.945
	10	-1.24		-0.615
	120	-0.69		-0.065
0.15	5	-0.74	+0.625	-0.115
	10	-0.72		-0.095
	120	-0.42		+0.205

12

0.5

1

0.5

12

5% 10%In

120%In

5% 10%In

120%In

120%I

5% 10%In

5~10 1

5~10 2.5~5

5~10

2.5~5

5~10

2~4

W₂ W₂₋ 3~6

W₂ W₂₊ 2~4



图12 两环磁分路补偿

40 60mm

H_b

W _b		H _b =I ₂ W _b /L _b	60
L _b			
W _b	H _b		H _b
B _b	b	$= [b \frac{W_2 - W_b}{W_2^2}] B_b H S_b L / B H_b S L_b$	61
		$f = k_f \cos - b + * 100 \%$	62
		$= k \sin - b + * 3438$	63
k _f	k		
		k _f = 0.6 0.8	64
		k = 0.4 0.6	65
62	63	50% I _n b	
		100% 120% I _n b	
62	63		
m		H _m	
55° 65°			
		H _m = 0.23 0.3A/cm	m =
		H _m = 0.3 0.5A/cm	m = 4055° 50°
			B-H

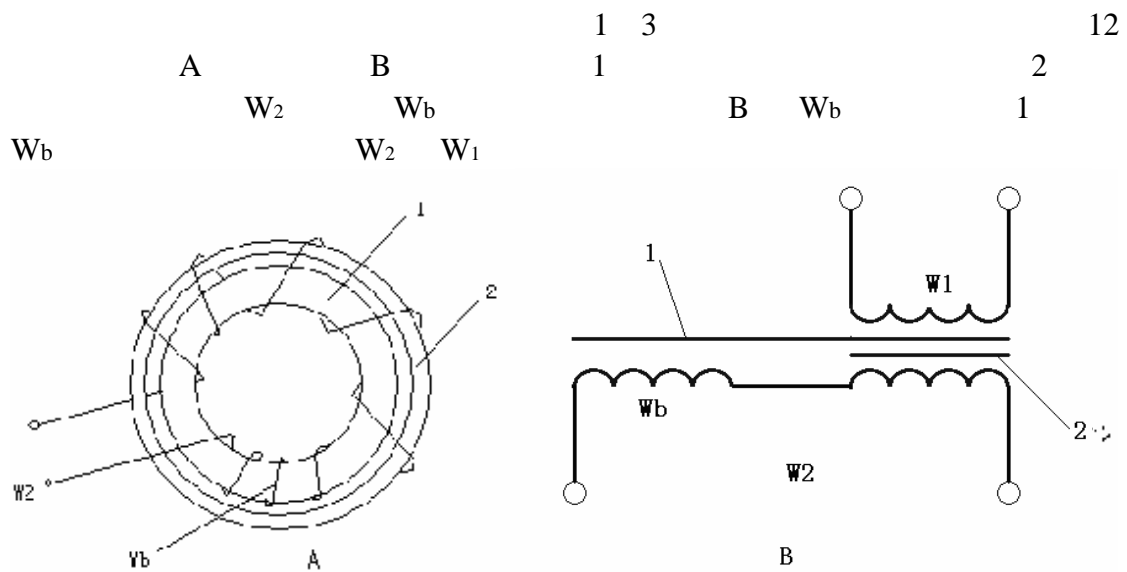
[34]

D42

D42
Hm=0.4A/cm

B-H

B-H

15

$$W_b = H_m L_b / 10\% \quad I_{2n} = 0.4 * 9 / 0.5 = 22.6$$

$$W_b = 23$$

[35]

150

D340



图 15 D42铁心B-H曲线

33 D340

Hm=0.2A/cm

$$W_b = H_m L_b / 10\% \quad I_{2n} = 0.2 * 15 / 0.5 = 18.8$$

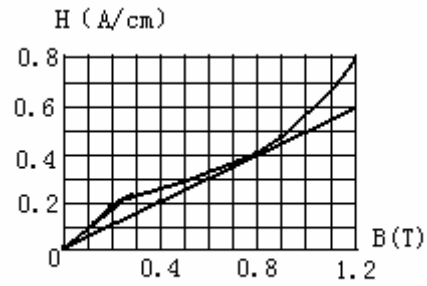
Wb=19

32 35

Wb

Wb

1

2

16

Wk



图 16 短路匝补偿

Wk,

Ek

$$E_k = \frac{W_k}{W_2} E_2$$

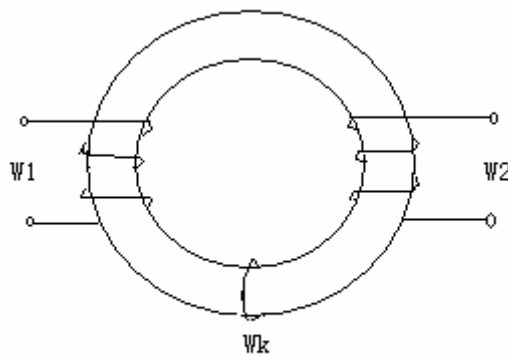
67

Wk

Rk

Xk 0

Ik

$$I_k = E_k / R_k = \frac{W_k}{W_2} * E_2 / R_k$$

68

$$I_k W_k = \left(\frac{W_k}{W_2} \right) * \left(\frac{E_2}{R_k} \right) * W_k$$

69

$$= \frac{W_k}{W_2} * \left[\frac{E_k + E_{b2}}{I_2 * (R_k + R_{b2} + r)} \right] \quad \frac{1}{W_2} * \frac{E_{b2}}{I_2 * (R_k + R_{b2} + r)} \quad 74$$

$$R_k \quad R_{b2} \quad W_k \quad W_{b2}$$

$$E_k \quad E_{b2}$$

$$f = - \sin \theta * 100\% \quad 75$$

$$= - \cos \theta * 3438 \quad 76$$

$\theta =$

$$7\% \quad 10\% \text{In} \quad \frac{E_{b2}}{I_2}$$

$$\frac{E_{b2}}{I_2}$$

W_b

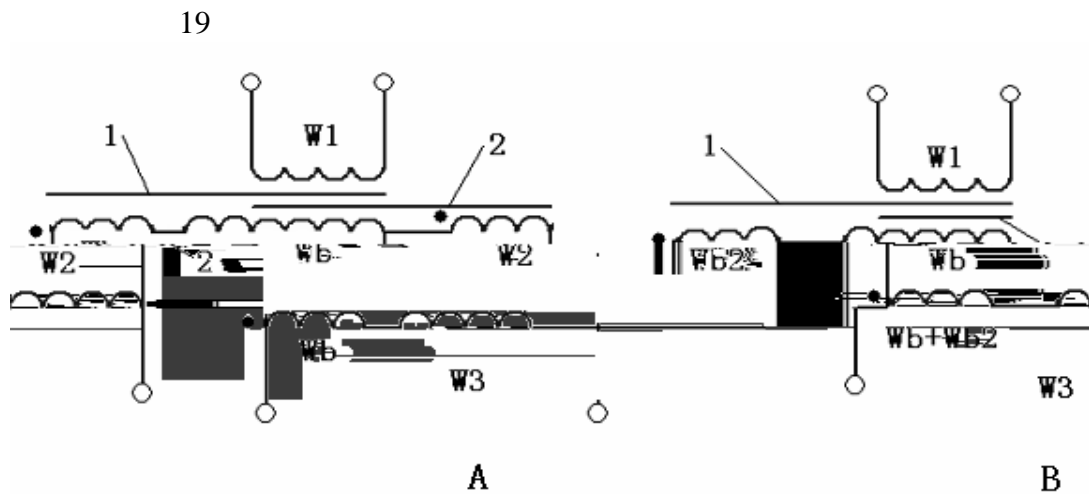

19

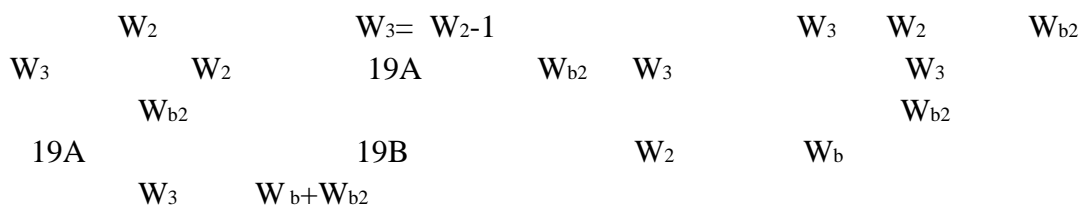

$$= \frac{1}{W_2} * \left[\frac{E_{b2}}{I_2} (R_2 + R_3 + R_{b2}) \right] \quad 77$$

$$E_{b2} \quad W_{b2}$$

$$f = - \sin \theta * 100\% \quad 78$$

$$= - \cos \theta * 3438 \quad 79$$

18 19

R_3

r

19

18

R_3

18

1

$I_2 Z$ C 80

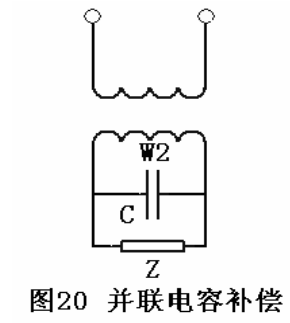

$$= - \cos \phi * 3438$$

83

$$2W_2 = \frac{W_3}{W_2} * 100 \quad CZ_{02} \quad \%$$

85

86

$$\begin{aligned}
& 22 \\
I &= C U_2 + E_3 = C I_2 [Z_1 + W_3/W_2 * Z_2] \\
&= C I_2 \{ [W_2 + W_3 / W_2] * Z_1 + W_3 + W_2 / Z_2 \} \quad 88 \\
&= I W_2 + W_3 / I_2 W_2 \\
&= 100 C \{ [W_2 + W_3 / W_2]^2 Z_1 + [W_3(W_2 + W_3)/W_2^2] Z_2 \} \quad 89 \\
f &= 100 C \{ [W_2 + W_3 / W_2]^2 X_1 + [W_3(W_2 + W_3)/W_2^2] X_2 \} * 100\% \quad 90 \\
&= 100 C \{ [W_2 + W_3 / W_2]^2 R_1 + [W_3(W_2 + W_3)/W_2^2] R_2 \} * 3438(\text{ } ^\circ) 100\% \quad 91 \\
Z_2 &= R_2 + jX_2
\end{aligned}$$

$$\begin{aligned}
[\quad 36] \quad & 5A \quad 20VA \quad 0.8 \\
& C = 1 \text{ f}
\end{aligned}$$

$$\begin{aligned}
Z_n &= S_n / I_n^2 = 20 / 5^2 = 0.8 \\
Z_x &= 25\% Z_n = 0.2 \\
82 \quad & 83
\end{aligned}$$

$$\begin{aligned}
f_n &= 100 C X_n = 100 C Z_n \sin \phi * 100\% \\
&= 100 * 1 * 10^{-6} * 0.8 * 0.6 * 100\% \\
&= 0.015\% \\
n &= -100 C R_n * 3438 = -100 C Z_n \cos \phi * 3438 \\
&= -100 * 1 * 10^{-6} * 0.8 * 0.8 * 3438 \\
&= -0.69 \text{ } ^\circ \\
C &= 1 \text{ F} = 1 * 10^{-6} \text{ F}
\end{aligned}$$

$$\begin{aligned}
f_x &= 25\% \quad f_n = 0.25 * 0.015 = 0.0038 \text{ } \% \\
x &= 25\% \quad n = 0.25 * -0.69 = -0.17 \text{ } ^\circ \\
[\quad 37] \quad & 36 \quad 2 \quad W_3 = 2W_2 \\
& Z_2 = R_2 = 0.2
\end{aligned}$$

$$\begin{aligned}
Z_{on} &= Z_n + Z_2 = 0.8 * 0.8 + j0.8 * 0.6 + 0.2 \\
&= 0.84 + j0.48 \\
Z_{ox} &= Z_x + Z_2 = 0.2 * 0.8 + j0.2 * 0.6 + 0.2 \\
&= 0.36 + j0.12 \\
86 \quad & 87
\end{aligned}$$

$$\begin{aligned}
f_n &= W_3 / W_2^2 * 100 C R_{on} * 100\% \\
&= 2^2 * 100 * 1 * 10^{-6} * 0.48 * 100\% \\
&= 0.06\% \\
n &= - W_3 / W_2^2 * 100 C R_{on} * 3438
\end{aligned}$$

$$= -2^2 \cdot 100 \cdot 1 \cdot 10^{-6} \cdot 0.84 \cdot 3438$$

$$= -3.63(\%)$$

$$f_x = \frac{W_3}{W_2} \cdot 2 \cdot 100 \cdot CR_{ox} \cdot 100\%$$

$$= 2^2 \cdot 100 \cdot 1 \cdot 10^{-6} \cdot 0.12 \cdot 100\%$$

$$= 0.015\%$$

$$x = - \frac{W_3}{W_2} \cdot 2 \cdot 100 \cdot CR_{ox} \cdot 3438$$

$$= -2^2 \cdot 100 \cdot 1 \cdot 10^{-6} \cdot 0.36 \cdot 3438$$

$$= -1.56(\%)$$

[38]

37

90 91

$$f_n = 100 \cdot C \left\{ \left[\frac{W_2 + W_3}{W_2} \right]^2 X + \left[\frac{W_3(W_2 + W_3)}{W_2^2} \right] X_2 \right\} \cdot 100\%$$

$$= 100 \cdot 10^{-6} \cdot [3^2 \cdot 0.8 \cdot 0.6 + 6 \cdot 0] \cdot 100\%$$

$$= 0.14\%$$

$$= -100 \cdot C \left\{ \left[\frac{W_2 + W_3}{W_2} \right]^2 R + \left[\frac{W_3(W_2 + W_3)}{W_2^2} \right] R_2 \right\} \cdot 3438$$

$$= -100 \cdot 10^{-6} \cdot [3^2 \cdot 0.8 \cdot 0.8 + 6 \cdot 0.2] \cdot 3438$$

$$= -7.5(\%)$$

$$f_x = 100 \cdot 10^{-6} \cdot [3^2 \cdot 0.2 \cdot 0.6 + 6 \cdot 0] \cdot 100\%$$

$$= 0.034\%$$

$$x = -100 \cdot 10^{-6} \cdot [3^2 \cdot 0.2 \cdot 0.8 + 6 \cdot 0.2] \cdot 3438$$

$$= -2.85(\%)$$

36 38 $W_3 = 2W_2$ 4 9
38 37 36

Z₀₂ Z

LMZ-0.5 200/5A

45/ 68*25	Z11	D340	5VA	cos =0.8
1.25	1.04	40	39	
R2 0.05	X2 0		Zn	Zx

$$Z_{on} = Z_n + R_2 = 0.16 + j0.12 + 0.05 = 0.21 + j0.12 \quad 0.24 \quad 30^\circ$$

$$Z_{ox} = Z_x + R_2 = 0.12 + j0.09 + 0.05 = 0.17 + j0.09 \quad 0.19 \quad 28^\circ$$

14

$$f_R = 0.5 \cdot \frac{1}{W_2} \cdot 100 = 0.5 \cdot \frac{1}{40} \cdot 100 = 1.25 \%$$

72

1

$$S_b = 2.5 * 0.035 = 0.88 \text{ cm}^2$$

33 D340 Hm=0.2A/cm
 $W_b = HmL_b / 10\% I_{2n} = 0.2 * 7.2 / 0.5 = 9$
 $W_b = 9$

60 63

200/5

15

14

	Zn=0.2		Zx=0.15	
I/In %	10	120	10	120
E2 V	0.12	1.44	0.095	1.04
B Gs	530	6300	380	4600
H A/cm	0.023	0.13	0.018	0.105
°	29	54	27	51
I ₀ W ₁ A	0.41	2.3	0.32	1.86
+ °	59	84	55	79
%	2.05	0.96	1.6	0.78
f %	-1.76	-0.95	-1.31	-0.77
	+36.5	+3.5	+31	+5.1

15

	Zn=0.2		Zx=0.15	
I/In %	10	120	10	120
Hb A/cm	0.2	2.4	0.2	2.4
Bb T	1.02	1.85	1.02	1.85
b °	60.5	20	60.5	20
- b+ °	-31.5	+36.5	-33.5	+32
b/	2.22	0.16	2.5	0.175
Gb/G	0.0535	0.0038	0.06	0.0043
%	0.94	0.065	1.05	0.076
fb %	+0.58	+0.036	+0.62	+0.045
b	-8.4	+0.65	-10.8	+0.7
fR %	+1.25	+1.25	+1.25	+1.25
R	0	0	0	0
f %	+0.07	+0.34	+0.56	+0.52
	+28.1	+4.1	+20.2	+5.8

10%In

$$H_b = I_2 W_b / L_b = 10\% * 5 * 9 / 7.2 = 0.2 \text{ A/cm}$$

D340B-H -H H_b=0.2A/cm B_b=1.02T

b=60.5°

$$- b+ = -60.5^\circ + 29 = -31.5^\circ$$

$$b/ = B_b/B * H/H_b = 10200/530 * 0.023/0.2$$

$$= 2.22 G_b/G = b/ * S_b L / S L_b$$

$$R_2 = L/A = 0.02 * 55/0.5 = 2.2$$

$$L = 2 * [30 + 5 + 15 + 5] * 500 = 55000 \text{mm} = 55 \text{m}$$

$$A = \pi/4 * 0.8^2 = 0.5 \text{mm}^2$$

$$X_2 = 0$$

$$5 \text{VA}$$

$$2.5 \text{VA}$$

$$Z_{on}$$

$$Z_{ox}$$

on

$$\cos \phi = 1$$

$$Z_{on} = Z_2 + Z_n = R_2 + R_n = 2.2 + 5 = 7.2$$

$$\phi_{on} = 0^\circ$$

$$Z_{ox} = Z_2 + Z_x = R_2 + R_x = 2.2 + 2.5 = 4.7$$

$$\phi_{ox} = 0^\circ$$

$$\cos \phi = 0.8$$

$$Z_{on} = Z_2 + Z_n = 2.2 + 4 + j3 = 6.9$$

$$\phi_{on} = \cos^{-1} (R_{on}/Z_{on}) = \cos^{-1} (6.2/6.9) = 26^\circ$$

$$Z_{ox} = Z_2 + Z_x = R_2 + R_x = 2.2 + 2 + j1.5 = 4.5$$

$$\phi_{ox} = \cos^{-1} (R_{ox}/Z_{ox}) = \cos^{-1} (4.2/4.5) = 21^\circ$$

$$Z_{on} = 7.2 \quad Z_{ox} = 4.7$$

$$5\% \quad 10\%$$

120%

17

17

Z ₀₂ ()	I _n %	E ₂ V	B (Gs)	H (A/cm)	()	(%)	cos φ = 1		cos φ = 0.8	
							f %	(F %	
7.2	5	0.36	80	0.005	20	0.53	-0.18	17	-0.38	13
	10	0.72	160	0.009	22	0.48	-0.17	15	-0.36	11
	120	8.6	1900	0.06	45	0.26	-0.18	6	-0.24	3
4.7	5	0.24	53	0.004	19	0.42	-0.14	14	-0.27	11
	10	0.47	100	0.006	21	0.32	-0.11	10	-0.21	8
	120	5.6	1200	0.04	39	0.18	-0.11	5	-0.16	3

$$Z_{02} = Z_{on} = 7.2 \quad 120\% I_n$$

$$E_2 = I_2 Z_{02} = 120\% I_n * 7.2 = 8.6 \text{ V}$$

$$B = 45 E_2 / W_2 S_k = 45 * 8.6 / (500 * 4.5 * 0.9) = 0.19 \text{T} = 1900 \text{Gs}$$

$$S = 30 * (100 - 70) / 2 = 450 \text{mm}^2 = 4.5 \text{cm}^2$$

$$K = 0.9$$

D340

B-H

-H

B = 1900Gs

H = 0.06A/cm

= 45°

$$f = HL / I_2 W_2 * 100 = (0.06 * 26.7 / 120\% * 500) * 100 = 0.26 \%$$

$$L = (100 + 70) / 2 = 267 \text{mm} = 26.7 \text{cm}$$

$$\cos \phi = 1$$

$$f = -\sin \phi = -0.26 \sin 45^\circ = -0.18 \%$$

$$= \cos \phi * 3438 = 0.26\% \cos 45^\circ * 3438 = 6.3$$

$$\cos \phi = 0.8$$

$$f = -\sin + = -0.26 \sin 45^\circ + 26^\circ = -0.24 \%$$

$$= \cos + *3438 = 0.26 \% \cos 45^\circ + 26^\circ *3438 = 2.9$$

$$+0.13\%$$

$$\cos = 1 \quad -8 \quad 0.69 \quad 0.51$$

$$0.69 \quad 1 \quad 0.65 \quad 1.5 \text{ F}$$

$$23$$

$$18$$

18

()	In %	f %	cos =1		cos =0.8		cos =1		cos =0.8	
			fc (%)	c ()	fc (%)	c ()	f %	()	f %	()
			5	5 10 120	+0.13	0	-8	+0.14	-6	-0.05
							-0.04	7	-0.09	5
							-0.05	-2	+0.03	-3
2.5	5 10 120	+0.13	0	-4	+0.07	-3	-0.01	10	-0.07	8
							+0.02	6	-0.01	5
							+0.02	1	+0.04	0

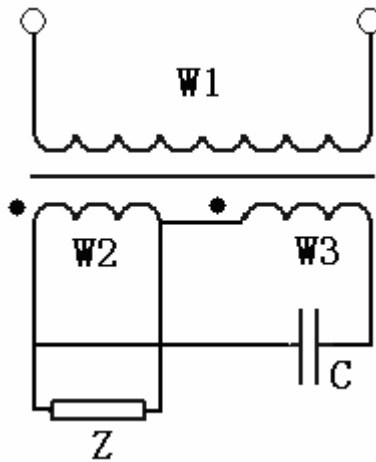

23

58

$$f = \frac{1}{W_2} * [D_b^2 / (D_b^2 + D_b^2)] * 100$$

$$= (1/5000 * [0.69^2 / (0.69^2 + 0.51^2)]) * 100$$

$$= 0.13 \%$$

82 83

$$f_c = 100 \text{ CX} * 100 = 100 * 1.5 * 10^{-6} * 3 * 100$$

$$= 0.14(\%)$$

X=3

cos =0.8

$$c = -100 \text{ CR} * 3438 = -100 * 1.5 * 10^{-6} * 4 * 3438$$

$$= -6.5()$$

R=4

cos =0.8

18 $\cos = 1$ $\cos = 1$ 0.8

$$f = f_+ f_+ f_c = -0.24 + 0.13 + 0.14 = +0.03 \%$$

$$= + c = 3 - 6 = -3$$

18
0.1 50%

$K_1 K_2 \dots$ $L_1 K_1$ $L_1 L_2 \dots$ K_1
 $L_1 K_1$
 1
 28 29
 (HE5 HEG4) (HE11
 HEG2) K_p
 K_p " " 10%—20% K_p
 " " 1%
 2—3
 2
 24 K
 R
 24 K
 R



图24 直流法检查绕组极性

1.5V1

R

K

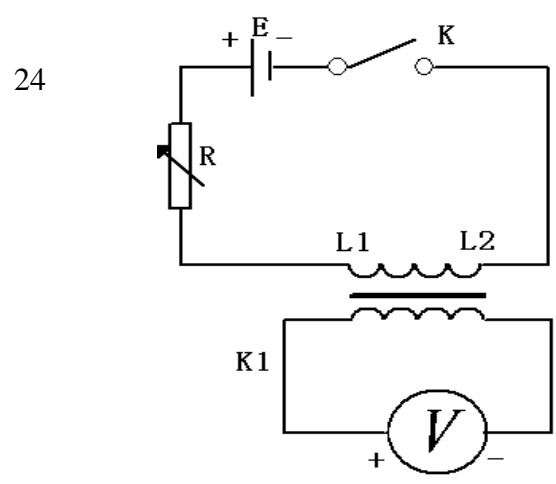
3

1--5V

10V

L1K2

25
L1L2



图25 串联法检查绕组极性

200mV 2V

5

10

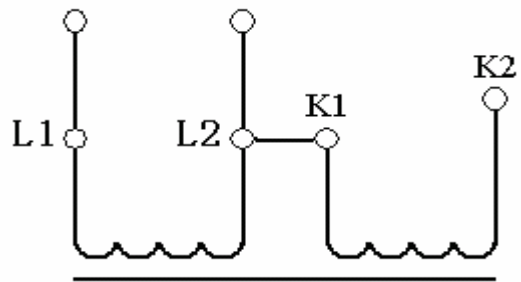
1

20% 50%

2-3

50% 20% 10%

2 ()

10—20

20% 50%

2-3

50% 20% 10%

1 0.01

10

5—5000/5A0.1

20%

200—1200

20

4

0.2T

$$H_t = 20.5 - 5 H_m$$

$$B_t = 1.5 - 2 B_m$$

19

	Hm(A/cm)	B(T)	Ht(A/cm)	Bt(T)
	0.4	0.8	1	0.3
	0.2	1	0.5	1.6
	0.02	0.4	0.1	0.7

$$H_t L_p = H_t L_p$$

10

$$I_t / I_{1n} = \frac{I_t W_1}{I_{1n} W_1} = \frac{H_t L_p}{I_{1n} W_1} * 100\%$$

[39] 0.1 5—5000/5 D340 92

1000 12 20 cm

19 $H_t = 0.5 \text{ A/cm}$ 92

$$I_t / I_{1n} = \frac{I_t W_1}{I_{1n} W_1} = (0.5 * 20) / 1000 = 3.2\%$$

0.1 5 5000/5 4%

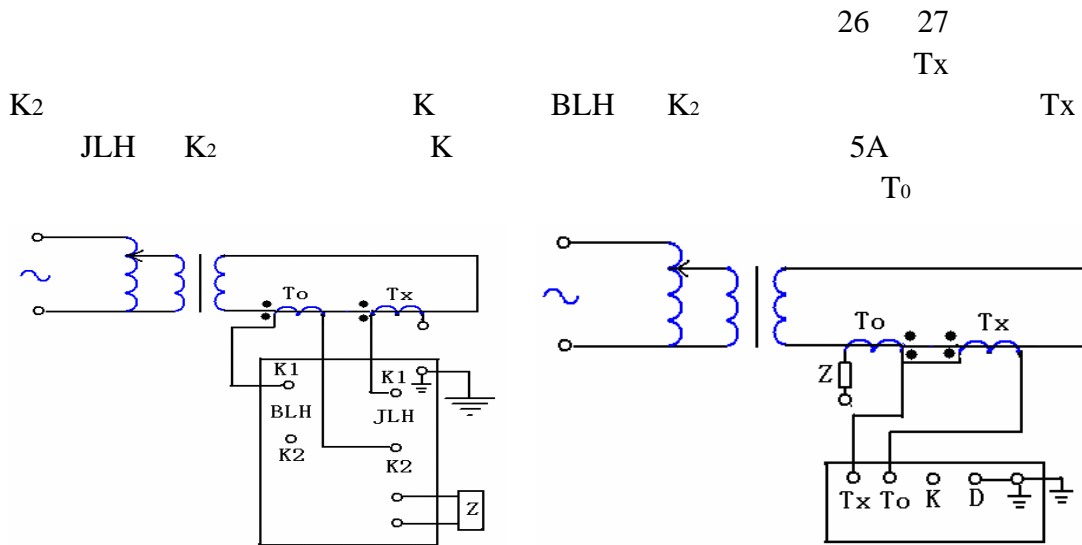

26 HE5

27 HEG

f		fx	x	
	$F_x = f \%$			93
	$x =$			94
f_0	0			
	$F_x = f + f_0 \%$			95
	$x = + 0$			96
			f	6
	10%			HE5
HE11	HEG2	HEG4		10
(5)	0.05		10	0.01

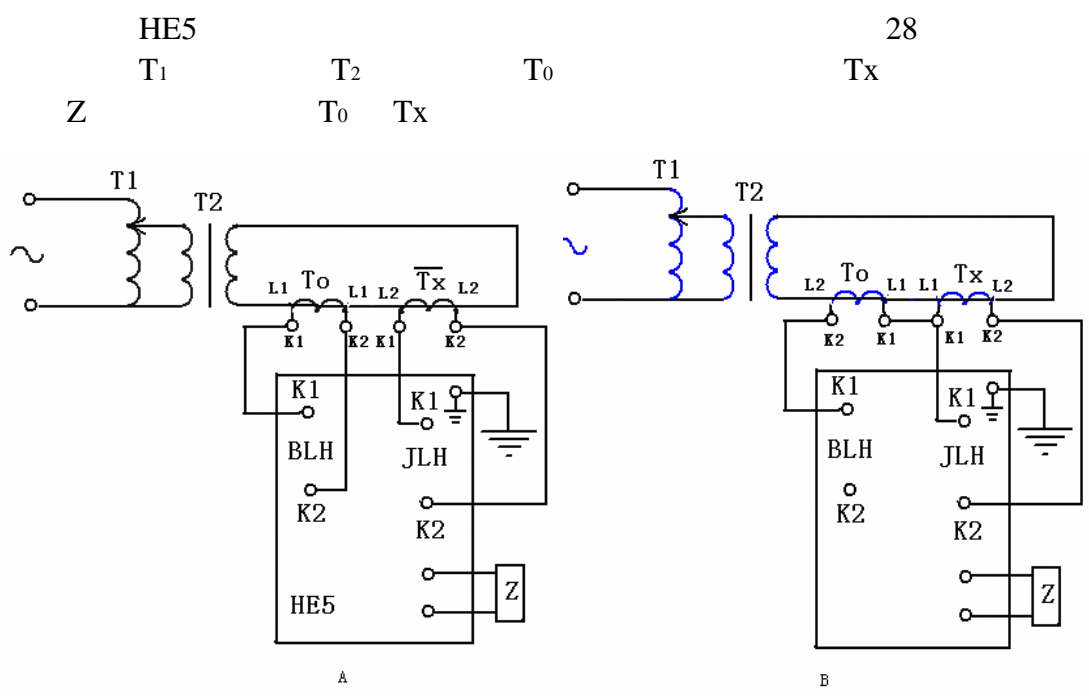

28 HE5

28A HE5

JLH K₁K₂ T₀ T_x K₁K₂ T₀ T_x BLH

28B

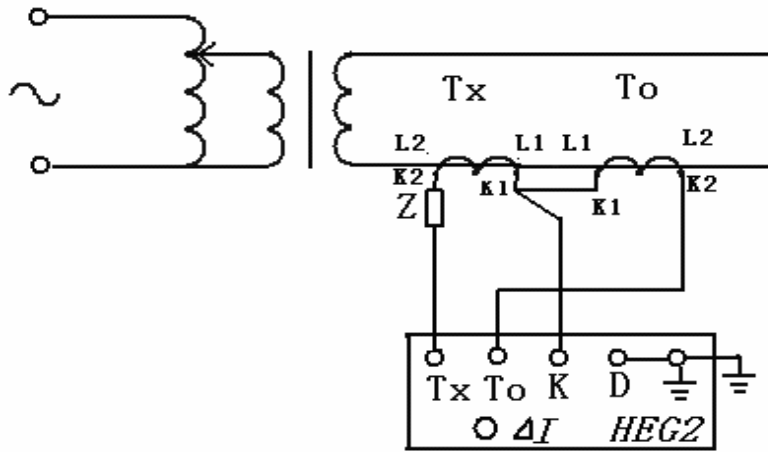

	29 HEG2			
	28		28 B	HEG2
0.09-+0.01		0.11±0.01 cos =1	0.02 cos =1	
		0.01 cos =1		0.05
HEG2		" 0.1 "	" 0.5 "	HEG2
HEG4		" %%"	" %%"	
		" %%"	" LC"	10 ⁻⁴ mH
	F			
HEG2				HEG2
	HEB		*1 *10 *100	
	0.1		*1	
	1*10 ⁻⁶			*10
HEG2				
	*1			
*0.1			(*0.01)	
		2—3		
		0.1A	0.1	
HE5				



B HE5 HEG2 5/5 1/1 30A

30

31 f

To Tx
 Ac

o Tx nIn-Ic n

T_x nI_n T_a T_b $100\%I_n$
 T_a T_b 0.2 T_x 0.5% Z
 T_b T_b T_x T_x Z

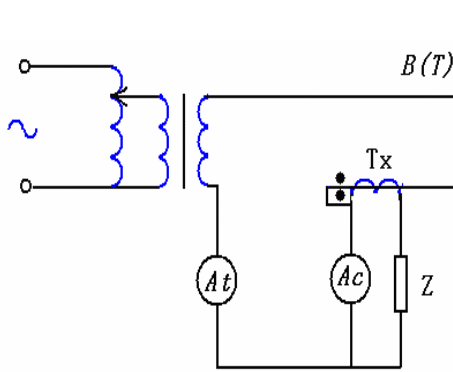

32

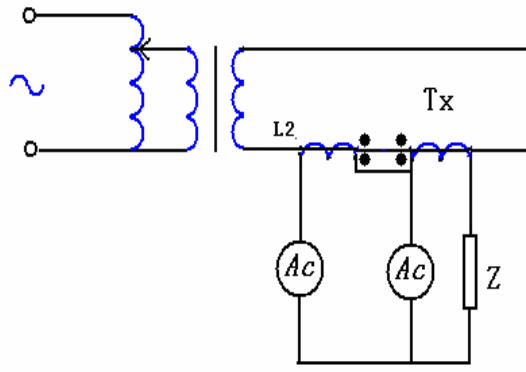

33

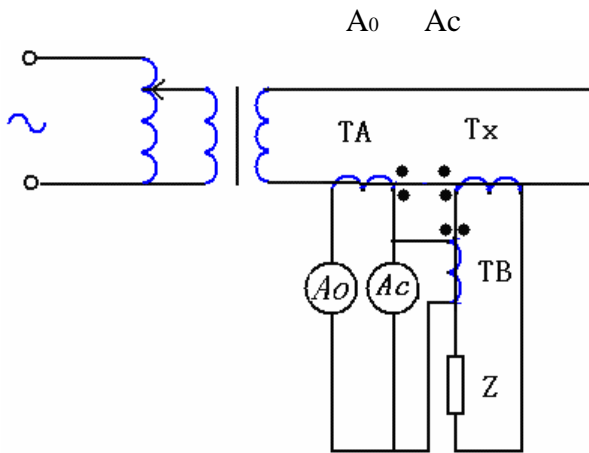

34

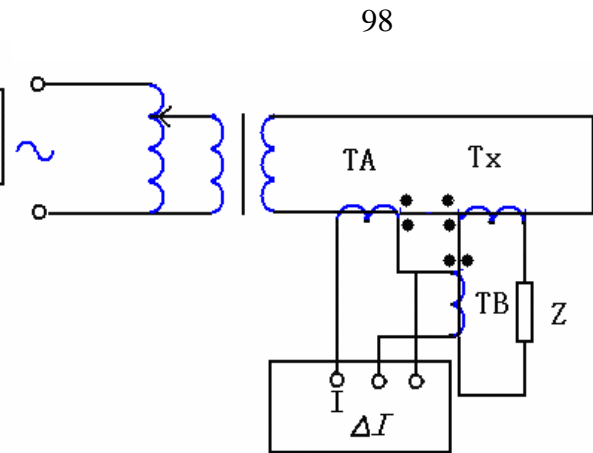

35 HEGF1

A_0 A_c 98
 T_A T_x T_A T_x
 A_0 A_c T_B Z
 T_B Z
 I ΔI

HEF1 35
 T_0 T_x A_0
 $In=5A$ 1% 3 $120\%I_n$
 10% 2% c 3
 n A/D
 36
 3

$$U = nI_2n(Z+Z_2) = nI_2nZ_{02} \quad 36 \quad U \quad 100$$

$$c = \frac{I_0/nI_2n}{8} * 100 = \frac{I_0/U}{8} * Z_{02} * 100 \quad \% \quad 101$$

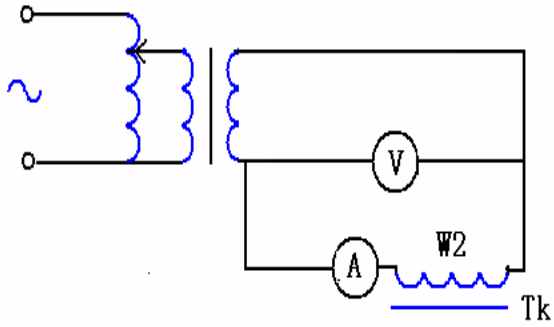

36

±10%

±3%

1 HEG2
HEG2
37

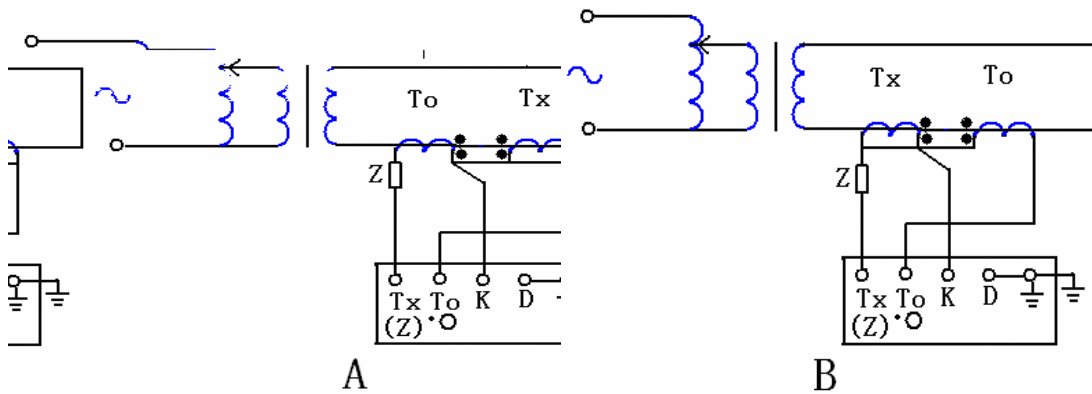

A

B

37A

37 HEG2

29

%%
T_o
HE11

Z
R X

37B $Z=R+jX$ 29 102

T_x
 R X $Z= - R+jX$ 103

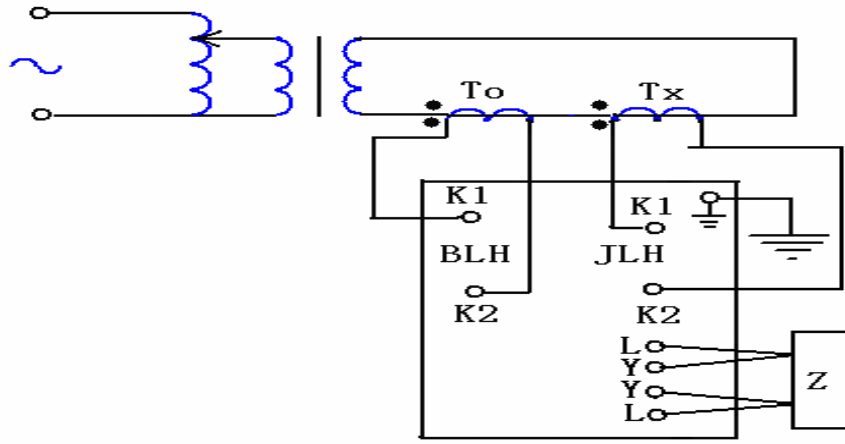

38 HE5

2 HE5
 HE5

38

HE5

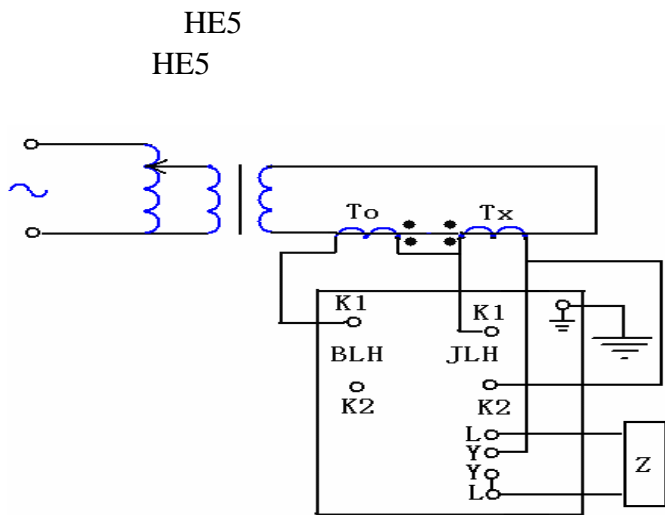

HE5
 HE5

28B

39

39

28B

T_x K2
 Y Y
 Y L
 R X
 39 HE5

L

$Z=R+jX$

104

5% 120%

				120%		
		HEG2		37		To
Tx		39				
R				Tx		
					0 250V	
		0 250V				
				5kVA	5kVA	
		U I S				
		S=UI VA				105
				28	29	
	1					
				5 50VA		
				5VA		5
50VA		20 150VA		10A		
	2					
						2000A
					S	
I _{in}		I _{in} 10A				
		S=50 200VA				106
		S=100VA I _{in} =10A				U=10V
I _{in} =0.1A		U=1000V				
		I _{in} =10 2000A				
		S=K ₁ I _{in} +50 200 VA				107
K ₁ ---		K ₁ =2 4 v				
		I _{in} 200A 50 200VA				

$S = K_1 I_{in} \text{ VA}$ 108
 $U = K_1 = 2 \text{ 4 V}$ 109
 $I_{in} = 250 \text{ A}$ $U = 4 \text{ V}$ $S = 4 * 250 = 1000 \text{ VA}$ $I_{in} = 1000 \text{ A}$
 $U = 4 \text{ V}$ $S = 4 * 1000 = 4000 \text{ VA}$
 $I_{in} = 2000 \text{ A}$

$S = K_2 I_{in}^2 \text{ VA}$ 110
 $K_2 = \dots$ $K_2 = 0.5 \text{ 1} * 10^{-3}$

$Z = K_2 = 0.5 \text{ 1 m}$ 111

$I_{in} = 10 \text{ A}$
 50 200VA $I_{in} = 10 \text{ 200A}$ 0.2 1KVA $I_{in} = 200 \text{ 2000A}$
 0.5 8KVA 2 4V $I_{in} = 2000 \text{ A}$ 10 KA 2 100KVA

105

$SYL1 \text{ 500VA}$
 250 V 5 V 100 A 15 V 32 A
 40 V 12 A 120 V 4 A 400 V 1.2 A 1200 V 0.4 A
 250 V
 (\dots)
 10 V $10/5$ 100 VA
 15 V 32 A 40 V 12 A
 $5\% \text{ 120\%}$ $1/5$ 100 VA
 120 V 4 A 400 V 1.2 A
 1 A 4 A 4 A
 4 A 4 A
 1 A 120 V 1 A 120%
 40 V 12 A
 250 V 40 V 1 A 1.2 A
 $10/5$ 15 V $1/5$ 120 V

$I_{in} = 10 \text{ A}$

100 VA $Z = 100 / 10^2 = 1$ $U = 10 \text{ V}$ $I_{in} = 10 \text{ A}$
 $Z = 10 / 1^2 = 100$ $U = 100 \text{ V}$ $I_{in} = 1 \text{ A}$

$SZ3-3$ 250 V
 3 kVA 1 V 3000

10V 50A 30V 10A
 500VA 300VA
 500/5 3 1500VA
 6 3kVA 3 3V
 3000/3=1000A 3kVA 500A
 1.5kVA 6 6V 3000/6=500A 3kVA
 $I_{in} = 2000A$
 $S = 0.5 \cdot 1 \cdot 10^{-3} \cdot 10000^2 = 0.5 \cdot 1 \cdot 10^5 VA = 50$
 $I_{in} = 10kA$ 109
 100kVA

10 20
 LSZ12-12
 250V 1V 12000 12kVA
 10kA 10000/5 10 12kVA
 8kVA 120% $I_{in} = 12kA$
 50 100kVA 84% 92%

()

40 1 W_b 1 2 1 2
 W_2 1 2 W_2 W_b
 I_0 I_2
 T_x f
 $= I_0/I_2 = f + j$ 112

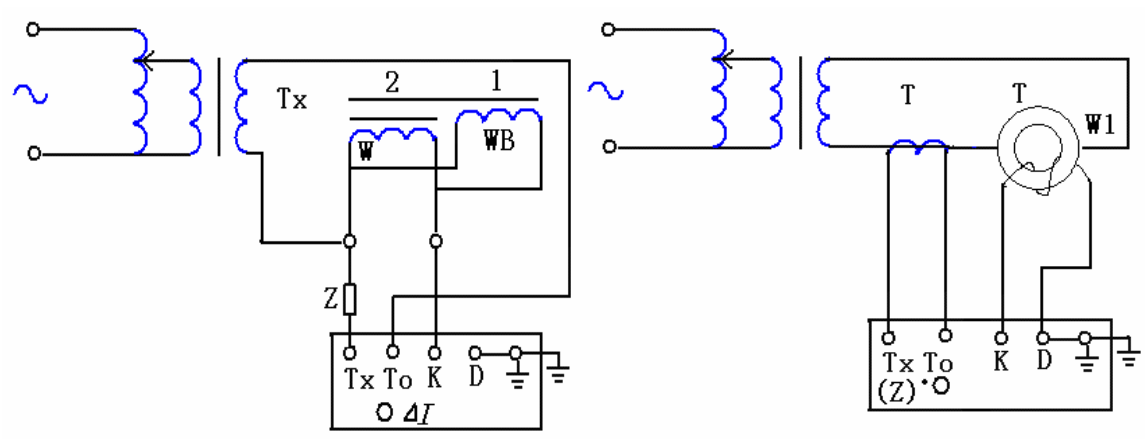

40

In=5 50/5 T

$W_1=1$ $W_c=5$
 $K_n=5/5$ $I=0.5 \quad 5A$ E_c

$Z=R+jK$
 $I \quad Z$
 $H=IW_1/L=I/L \quad A/cm$
 $L—$ cm
 $B=45E_c/W_cSk=47.4IZ/S$
 $k=0.95 \quad W_c=5$
 $S—$ cm^2
 $=tg^{-1} \quad X/R$

$H \quad B$ $B-H$ $-H$
D340 1 D310 2 $B-$ $-H$